

DATA  
OUTPUT

## MINI DIGITAL HEIGHT GAUGES

- Non waterproof
- Resolution: 0.01mm/0.0005"
- Buttons: on/off, zero, mm/inch
- Automatic power off, move the digital unit to turn on power
- Carbide tipped scriber
- With fine adjustment
- Made of stainless steel
- Battery CR2032
- Optional accessory: dial test indicator holder (code **7151-CL1**)



**1154-150**

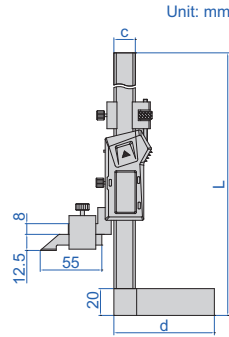

scriber (included)

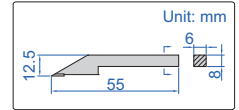

dial test indicator holder (optional)

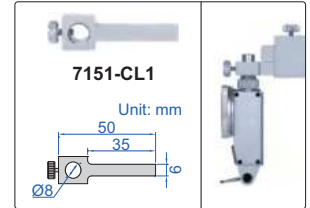

Code	Range	Accuracy	L	c	d	Data output cable (optional)
<b>1154-150</b>	0-150mm/0-6"	±0.03mm	280mm	16mm	75mm	<b>7315-25</b> (receiver is needed) page 5, <b>7214-25</b> page 11, <b>7302-21</b> page 20
<b>1154-200</b>	0-200mm/0-8"	±0.03mm	340mm	20mm	90mm	<b>7315-22</b> (receiver is needed) page 5, <b>7214-22</b> page 11, <b>7302-22</b> page 20

Built-in wireless (receiver code 7315-2/3/6/7/8/9 is needed)

Code	Range	Accuracy	L	c	d
<b>1154-150WL</b>	0-150mm/0-6"	±0.03mm	280mm	16mm	75mm

## MINI VERNIER HEIGHT GAUGES

- Graduation: 0.02mm/0.001"
- Carbide tipped scriber
- Made of stainless steel (except the base)
- Satin chrome plated scale
- Optional accessory: dial test indicator holder (code **7151-CL1**)



**1253-200**

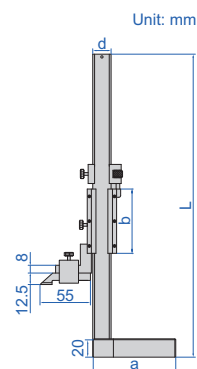

scriber (included)

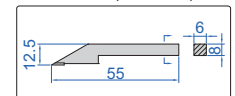

dial test indicator holder (optional)

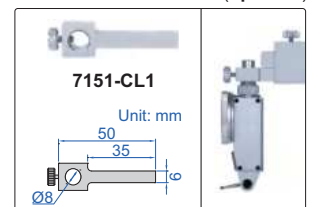

Code	Range	Accuracy	L	a	b	d
<b>1253-150</b>	0-150mm/0-6"	±0.03mm	265	75	57	16
<b>1253-200</b>	0-200mm/0-8"	±0.03mm	325	90	70	20

## VERNIER HEIGHT GAUGES

- Graduation: 0.02mm/0.001"
- Adjustable main scale to set zero
- Carbide tipped scribe
- Made of stainless steel (except the base)
- Satin chrome plated scale
- Supplied with magnifier
- With fine adjustment
- Supplied with dust cover
- Optional accessory: dial test indicator holder (code **6293-6**), clamp for protractors (code **2372-CLAMP**)

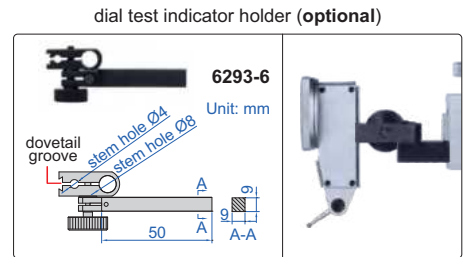
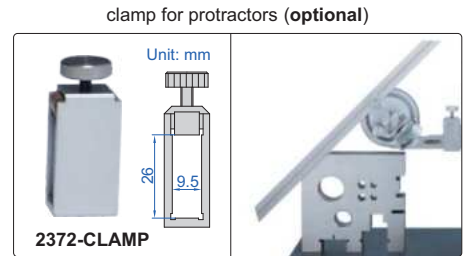
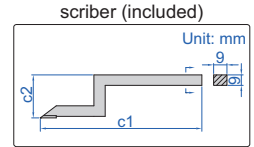
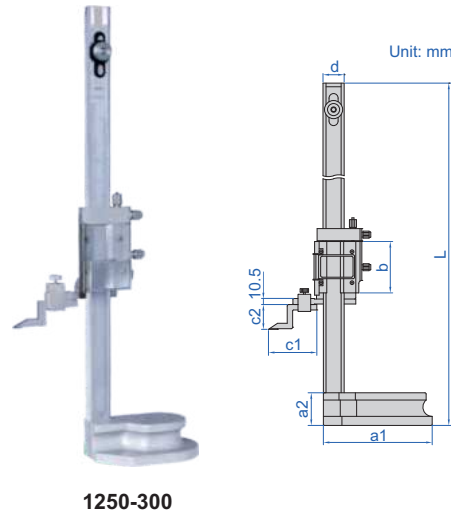

Code	Range	Accuracy	L	a1	a2	b	c1	c2	d
<b>1250-300</b>	0-300mm/0-12"	±0.04mm	545	135	43	75	80	30	28
<b>1250-450</b>	0-450mm/0-18"	±0.05mm	720	180	54	85	80	41	35
<b>1250-600</b>	0-600mm/0-24"	±0.05mm	870	180	54	85	80	41	35

## VERNIER HEIGHT GAUGES (BASIC TYPE)

- Graduation: 0.02mm/0.001"
- Carbide tipped scribe
- Made of stainless steel (except the base)
- Satin chrome plated scale
- With dial test indicator holder
- Supplied with dust cover

**POPULAR MODEL**

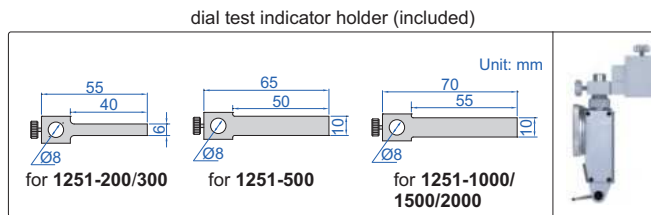
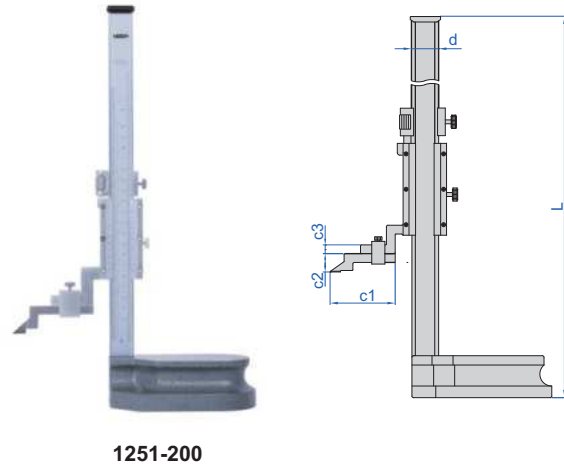

Code	Range	Accuracy	L	c1	c2	c3	d	e	f
<b>1251-200</b>	0-200mm/0-8"	±0.03mm	370	76	25	10	23	6	8
<b>1251-300</b>	0-300mm/0-12"	±0.04mm	470	76	25	10	23	6	8
<b>1251-500</b>	0-500mm/0-20"	±0.05mm	720	105	25	12	30	10	12
<b>1251-1000</b>	0-1000mm/0-40"	±0.07mm	1275	110	39	15	50	10	15
<b>1251-1500</b>	0-1500mm/0-60"	±0.11mm	1790	110	39	15	50	10	15
<b>1251-2000</b>	0-2000mm/0-80"	±0.14mm	2290	110	39	15	50	10	15

